



Installation & Operation Manual HF Series

WARNING!

To minimize the risk of serious injury and property damage:

- Do not exceed maximum operating pressure & temperature
- Do not open vessel until pressure has been relieved
- Read & follow instructions & safety information in this manual

Contents

- I. General Warnings
- II. Filter Installation & Start-up
- III. Shutdown
- IV. Media Replacement
- V. Seal Compatibility & Bolt Torque Values

Note: Keep this IOM in a protected pouch & permanently retain on or adjacent to filter vessel.

I. GENERAL WARNINGS

WARNING! Never use cover davit arm to lift vessel. Damage to lift assembly will result. On smaller vessels, use a sling with safety hooks equally spaced around vessel eyenuts. Larger vessels will have lifting lugs. See bill of lading for vessel weight (**see figure 1**).

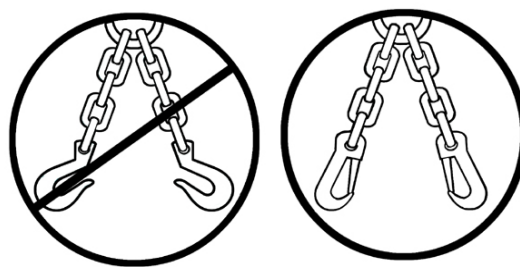

Figure 1

WARNING! USE PROTECTIVE CLOTHING. Operator should wear protective clothing including protective gloves and face shield. If handling hot liquids, the operator should wear heat resistant clothing made from materials such as Nomex® to avoid possible burning or scalding. Refer to the material safety data sheets (MSDS) for specific handling instructions.

WARNING! Operating vessel with damaged or worn parts could cause serious injury and/or damage. Inspect vessel interior and all components for wear, corrosion or damage. Replace all damaged components.

WARNING! Do not exceed the operating limits of this vessel and gasket. Property damage, serious injury or death can result if limits are exceeded. The maximum vessel operating pressure and temperature is stamped on the ASME code plate.

WARNING! The maximum operation temperature of this vessel may be limited by the closure seal o-ring material. The maximum operating temperature may be lower than the maximum design temperature stamped on the vessel nameplate. The maximum operating temperature can be increased up to the maximum design temperature by substituting an appropriate alternate o-ring gasket material.

In all cases, it is extremely important to match the temperature and chemical compatibility of the seal with actual conditions. Reference table 1 on page 3 for general guidelines.

II. FILTER INSTALLATION & START-UP

Start-up Procedure

1. Clean and inspect closure o-ring and o-ring groove. Lubricate o-ring with a suitable lubricant that is compatible with the seal material & the application.
2. Close cover onto vessel. Do not slam the cover against the vessel. Damage to the seal or sealing surfaces may occur. Swing bolts forward to engage cover (**see figure 2**). Hand tighten bolts.
3. Tighten bolts in an alternate criss-cross pattern. Do not apply excessive torque to the nuts as permanent distortion to the filter may result. Maximum torque applied to the bolting should not exceed the values found in table 2 on page 3 of this document.
4. Close drains and open vent plug.
5. Open inlet valve and allow vessel to fill slowly taking care to not allow process fluid to spray from the vent.
6. When air is expelled from vent and liquid begins to bleed from vent, close the vent plug.
7. Open outlet valves.

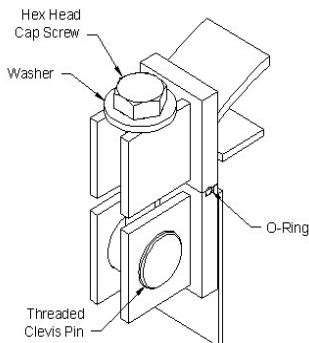
Figure 2

III. FILTER SHUTDOWN

WARNING! Do not service this vessel while inlet or outlet valves are open or while unit contains pressure. Do not, at any time, loosen closure bolts before draining. Failure to open drain and vent will result in pressurized liquid being trapped in vessel. Pressurized liquid will spray out when the bolts are loosened which could cause death, serious injury or property damage.

WARNING! USE PROTECTIVE CLOTHING! Operator should wear protective clothing including protective gloves and face shield. If handling hot liquids, the operator should wear heat resistant clothing made from materials such as Nomex® to avoid possible burning or scalding. Refer to the material safety data sheets (MSDS) for specific handling instructions.

Shutdown Procedure

1. Before opening vessel, turn off pump and lock it out.
2. Close inlet and outlet valves (**see figure 3**). Inlet or pressure side should always be closed first.
3. Open vent valve. Make sure the valve is piped such that escaping fluids do not cause personal injury or property damage.
4. Check pressure gauges to make sure the vessel's internal pressure is zero. Note: A DIFFERENTIAL pressure gauge connected between the inlet and outlet WILL NOT show internal pressure. Differential pressure gauges are usually marked "PSID" on the gauge face.
5. Open bottom drain. Gravity will move fluid through drain. After vessel has drained, close drain valve.
6. Loosen cover eye nuts, hex nuts or hex bolts, as supplied, and swing nut and bolts away from cover (**see figure 2**).
7. Swing cover away from vessel taking care not to damage the cover and sealing surfaces.

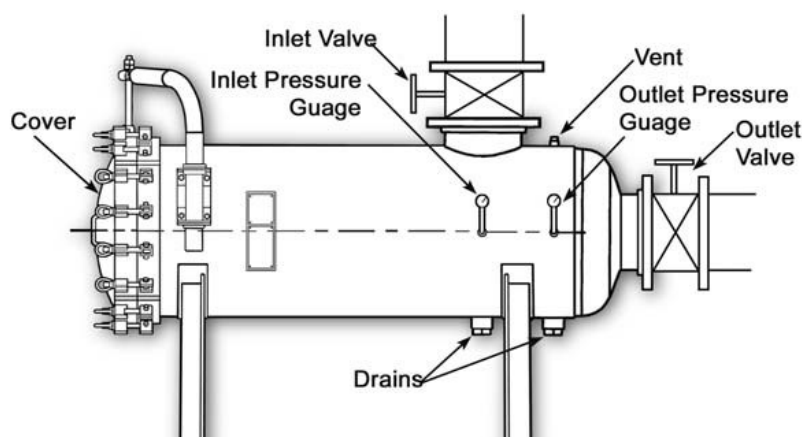
**Figure 3**

IV. MEDIA REPLACEMENT

1. Follow shutdown procedure in Section III.
2. Remove or swing away the cartridge hold down device.
3. Remove the filter cartridges by grasping the handle and pulling outwards. Dispose of all spent cartridges.
4. Lubricate new cartridge o-ring with suitable lubricant (or water).
5. Insert the cartridge into the support basket until it contacts the bottom edge of the basket support plate.
6. Give a sharp push or rap on the cartridge end to seat the o-ring.
7. Re-install the cartridge hold down device.
8. Refer to Section II (Startup Procedure).

V. SEAL COMPATIBILITY & BOLT TORQUE VALUES

Notice: Standard vessels are designed to use gaskets made of self energizing material such as Buna-N, EPR, or Viton®. Since the torque requirement to seal a vessel with these seals is minimal, it is normally not necessary to use extensions or cheater bars when torquing bolts & nuts. Standard vessels are not designed to use gaskets made of non-energizing material or rope type gaskets. These types may require tightening torque beyond that which the vessel is designed for causing damage to vessel. Reference table 2 below for maximum torque values.

READ BEFORE OPERATING

Warning! The maximum operation temperature of this vessel may be limited by the closure seal (o-ring or gasket) material. The maximum operating temperature may be lower than the maximum design temperature stamped on the vessel nameplate. The maximum operating temperature can be increased up to the maximum design temperature by substituting an appropriate alternate gasket material.

In all cases, it is extremely important to match the temperature and chemical compatibility of the seal with actual conditions. Reference table 1 below for general guidelines.

Table 1 - Properties of Gasket Materials

	Max. Oper. Temp. °F.	Resistance to Acids	Resistance to Alkalies	Resistance to Petroleum Oils	Resistance to Water Swelling	Resistance to Animal and Vegetable Oils	RESISTANCE TO SOLVENTS			
							Lacquers and Thinners	Aliphatic Hydrocarbons, Gasoline, etc.	Aromatic Hydrocarbons, Benzene, etc.	Oxygenated Ketones, etc.
Nitrile (Buna N)	250	Poor	Poor	Excellent	Excellent	Excellent	Poor	Excellent	Fair	Good
Neoprene	250	Good	Good	Good	Good	Good	Poor	Good	Fair	Poor
Butyl	250	Excellent	Excellent	Poor	Excellent	Excellent	Excellent	Poor	Poor	Good
Ethylene Propylene (EPR)	300	Excellent	Excellent	Poor	Good	Good	Good	Poor	Poor	Good
Fluorocarbon (Viton®)	400	Excellent	Poor	Excellent	Excellent	Excellent	Poor	Excellent	Excellent	Poor
PTFE (Teflon®)	500	Excellent	Excellent	Excellent	Excellent	Excellent	Excellent	Excellent	Excellent	Excellent
Silicone	500	Good	Good	Poor	Excellent	Excellent	Poor	Poor	Poor	Excellent

Note: This table shows the general characteristics of various gasket materials. Consult the Parker Catalog CAT-500-XX USA materials selection chart or ask a Wessels Application Engineer for assistance with your specific application.

Table 2 – Maximum Cover Bolt Torque Values

Nominal Bolt Diameter	Carbon Steel Bolt – Max Torque ft-lb	Stainless Steel Bolt – Max Torque ft-lb
5/8	50	30
3/4	80	50
1	200	125
1-1/8	295	185
1-1/4	415	265

Questions? Call a Wessels Application Engineer for assistance at (317) 898-9800